



IN-LINE MIXED FLOW DUCT FANS

TD-MIXVENT Series

Range of **low profile** in-line mixed flow duct fans manufactured in tough reinforced **plastic** (from 160 to 800 models) or with metal casing steel finished in a tough epoxy-polyester paint coating (from 1000 to 6000 models). The unique design of the support bracket allows the motor and impeller assembly to be fitted or removed without dismantling the adjacent ducting.

Motors

160 – 2000 models: Motors are IP44, class B, with ball bearings and safety thermal overload protection.

Direct 2-speed connection and also suitable for voltage speed control.

Electrical supply:

Single phase 230V 50/60Hz.

4000 and 6000 models: Motors are IP54, class F, with ball bearings and safety thermal overload protection.

Suitable for voltage speed control.

Electrical supply:

Single phase 230V 50/60Hz.

Additional Information

MIXVENT TD-T models fitted with a Run-On-Timer adjustable within 1 and 30 minutes and one-speed motor not suitable for speed control.



0 016982 603078



The MIXVENT-TD fans offer the ideal in-line duct fan solution for a wide range of general residential or commercial ventilation application into.



Low profile

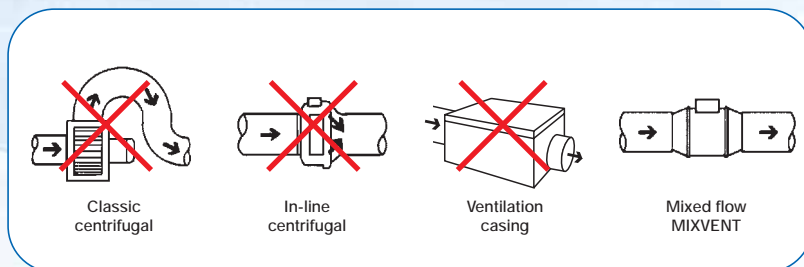

The low profile of the MIXVENT-TD fans makes them the most effective solution for installations where the space of installation is limited such as false ceilings.

Easy to mount



Fix the support bracket



Place the impeller and motor assembly



Carry out the wiring connections



Connect the ducts

Easy maintenance



The unique design of the support bracket allows the motor and impeller assembly to be fitted or removed without dismantling the adjacent ducting

Flexible mounting position

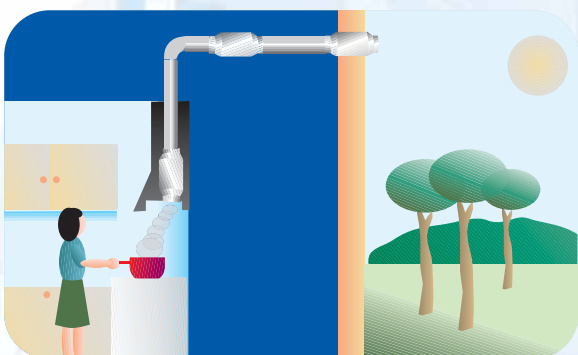

Can be mounted at any place of the air duct

Models with Run-On-Timer



MIXVENT-TD-T models (from 160 to 800 models) are fitted with an adjustable timer between 1 and 30 minutes and are supplied with a one-speed motor not suitable for speed control

■ Practical examples of installation of the TD-MIXVENT range

The MIXVENT-TD range provides a large number of solutions for small and large ventilation installations.

General extract installation

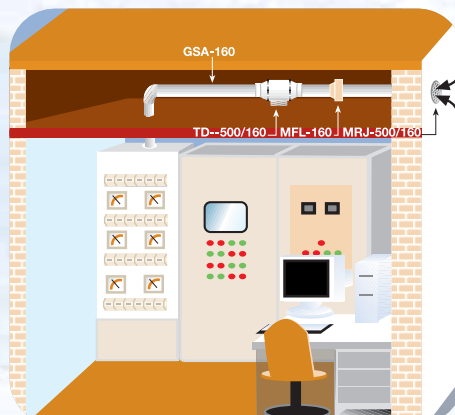

Control panel

Localised exhaust point installations

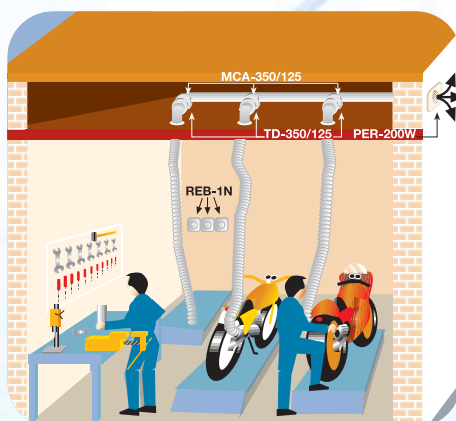

Workshop

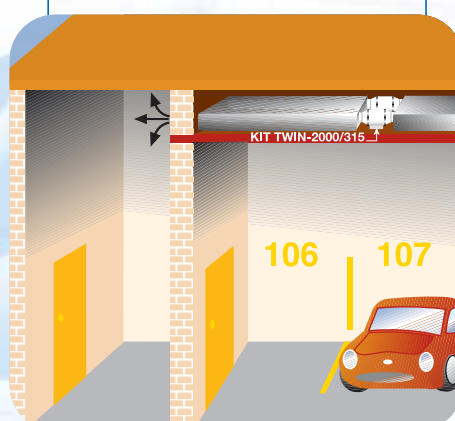

Parkings

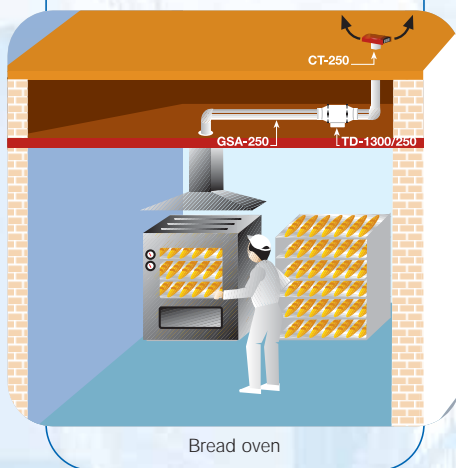

Bread oven

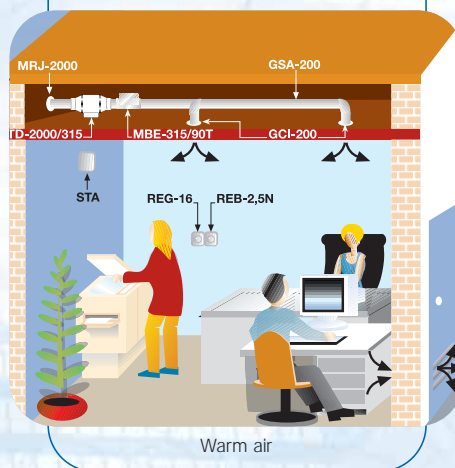

Warm air

Drying installations

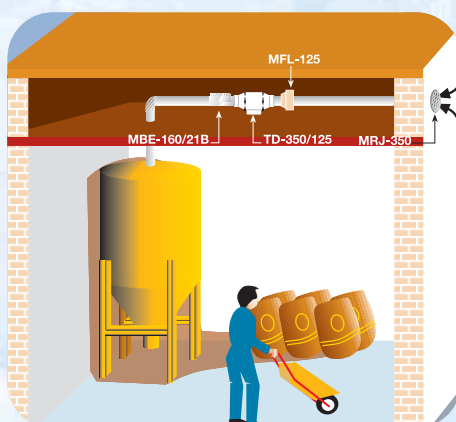

Dried fruit hopper

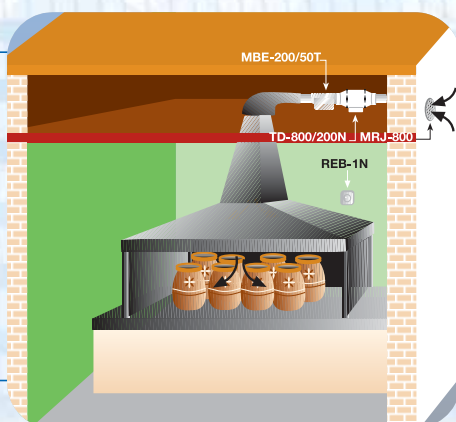

Drying ceramics tunnel

Residential & Commercial



Screen-printing workshop

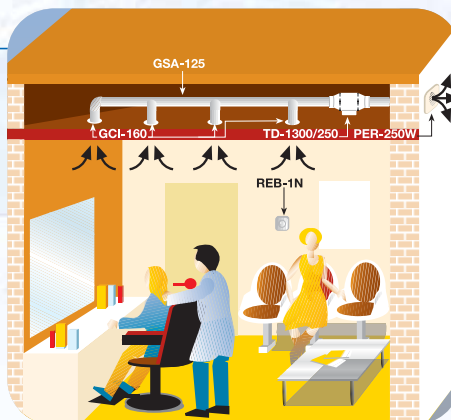

Hair salon



Meeting room

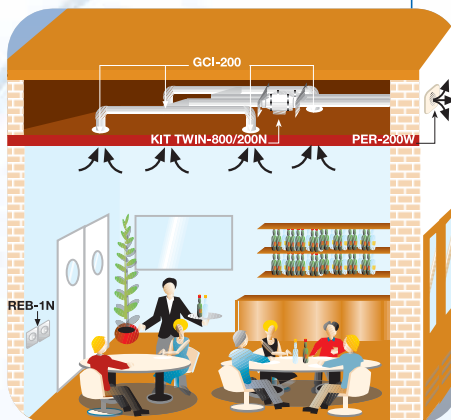

Catering

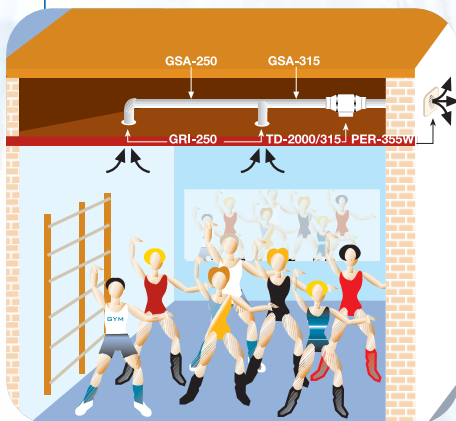

Gym

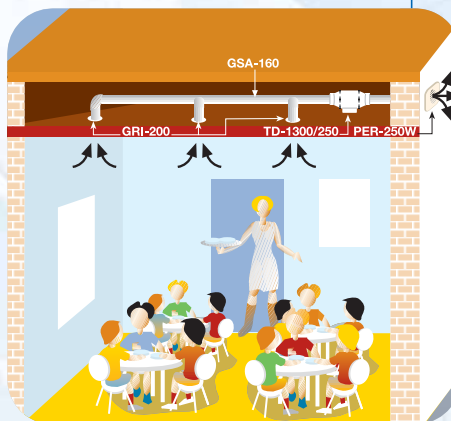

Children's dining hall

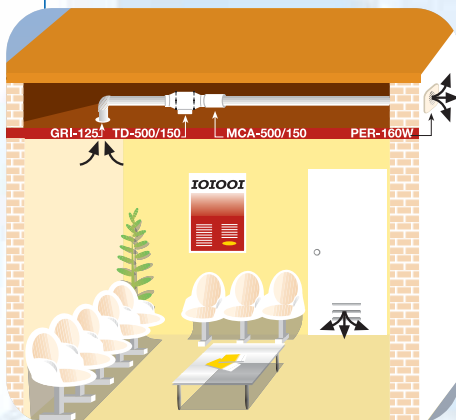

Waiting room in a health care center

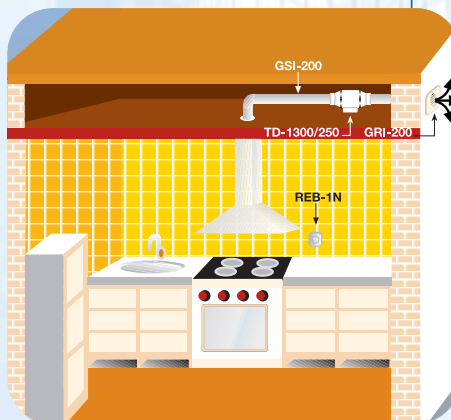

Domestic kitchen extract hood

■ Design characteristics

	160	250	350	500	800	800N	1000	1300	2000	4000	6000
Polypropylene casing	•	•	•	•	•	•					
Steel casing							•	•	•	•	•
ABS impeller	•	•	•	•	•	•					
Aluminium impeller							•	•	•	•	•
Protection class	II	II	II	II	II	II	I	I	I	I	I
Thermal protection by fuse	•	•	•								
Self- resetting thermal protection				•	•	•	•	•	•	•	•
Ball bearings greased for life	•	•	•	•	•	•	•	•	•	•	•
1 speed controllable motor										•	•
2 speed controllable (*) motor	•	•	•	•	•	•	•	•	•		

(*) Models with Run-On-Timer fitted (TD-MIXVENT-T) are not controllable.

■ Technical characteristics

TD-MIXVENT	Speed (r.p.m.)	Maximum power absorbed (W)	Maximum absorbed current (A)	Airflow at free discharge (m ³ /h)	Maximum operating temperature (°C)	Sound pressure level* (dB(A))	Ø Duct (mm)	Weight (kg)
TD-160/100 N SILENT NEW	2500	20	0,16	180	40	24	100	1,4
	2200	12	0,10	140	40	21		
TD-250/100	2200	24	0,11	240	40	31	100	2,0
	1850	18	0,10	180	40	26		
TD-350/125	2250	30	0,13	360	40	33	125	2,0
	1900	22	0,10	280	40	28		
TD-500/150	2500	50	0,22	580	60	33	150	2,7
	1950	44	0,19	430	60	29		
TD-500/160	2500	50	0,22	580	60	33	160	2,7
	1950	44	0,19	430	60	29		
TD-800/200N	2780	70	0,30	880	60	37	200	4,9
	2480	60	0,26	700	60	33		
TD-800/200	2500	120	0,50	1100	60	39	200	4,9
	2000	100	0,45	800	60	33		
TD-1000/250	2800	125	0,50	1010	60	40	250	9,4
	2610	85	0,35	900	60	38		
TD-1300/250	2520	180	0,80	1300	60	43	250	9,4
	2000	140	0,60	1100	60	39		
TD-2000/315	2700	255	1,20	2000	60	47	315	14,0
	2000	160	0,80	1550	60	42		
TD-4000/355	1400	345	1,53	3800	40	44	355	19,0
TD-6000/400	1400	665	2,97	5500	40	44	400	26,0

*Sound pressure level radiated at 3 m at free air conditions with rigid ducts at the inlet and at the outlet.

TD-MIXVENT-T	Speed (r.p.m.)	Maximum power absorbed (W)	Maximum absorbed current (A)	Airflow at free discharge (m ³ /h)	Maximum operating temperature (°C)	Sound pressure level* (dB(A))	Ø Duct (mm)	Weight (kg)
NEW TD-160/100 NT SILENT	2500	20	0,16	180	40	24	100	1,4
TD-250/100 T	2200	24	0,11	240	40	31	100	2,0
TD-350/125 T	2250	30	0,13	360	40	33	125	2,0
TD-500/150 T	2500	50	0,22	580	60	33	150	2,7
TD-500/160 T	2500	50	0,22	580	60	33	160	2,7
TD-800/200 T	2500	120	0,50	1100	60	39	200	4,9

*Sound pressure level radiated at 3 m at free air conditions with rigid ducts at the inlet and at the outlet.

■ Acoustic power spectrum in dB(A), for every frequency band, at the inlet and radiated, at high speed

NEW

AT INLET	63	125	250	500	1000	2000	4000	8000
TD-160/100 N SILENT	24	32	39	46	52	49	40	21
TD-250/100	28	47	46	53	52	47	39	33
TD-350/125	35	47	46	53	54	50	41	33
TD-500/150	32	35	55	57	59	62	56	48
TD-500/160	32	35	55	57	59	62	56	48
TD-800/200N	37	42	62	64	66	64	60	52
TD-800/200	37	47	61	63	68	67	64	54
TD-1000/250	35	45	58	66	72	69	62	54
TD-1300/250	37	52	64	67	75	73	66	61
TD-2000/315	41	57	66	71	77	74	67	62
TD-4000/355	40	49	61	66	73	70	66	57
TD-6000/400	43	56	67	72	76	74	69	60

NEW

RADIATED	63	125	250	500	1000	2000	4000	8000
TD-160/100 N SILENT	24	24	37	34	36	41	32	21
TD-250/100	27	46	45	44	43	43	32	25
TD-350/125	33	46	46	47	47	45	33	24
TD-500/150	25	32	43	39	44	53	42	29
TD-500/160	25	32	43	39	44	53	42	29
TD-800/200N	26	32	48	47	52	53	44	31
TD-800/200	29	36	47	46	54	57	48	33
TD-1000/250	23	34	44	46	58	57	46	43
TD-1300/250	22	36	39	47	60	59	52	47
TD-2000/315	29	41	52	55	64	63	57	53
TD-4000/355	31	49	55	55	63	57	51	40
TD-6000/400	30	53	59	55	61	55	54	45

■ Dimensions (mm)

TD-160/100 N SILENT **NEW**

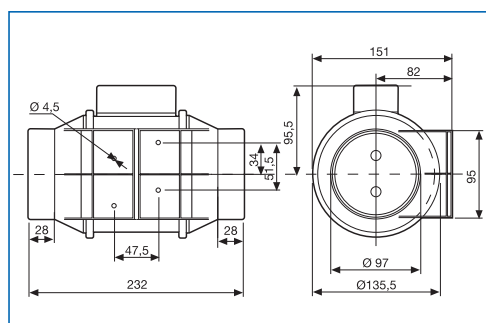

TD-250 to TD-2000

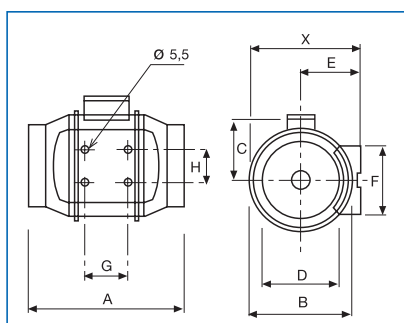

TD-4000 / TD-6000

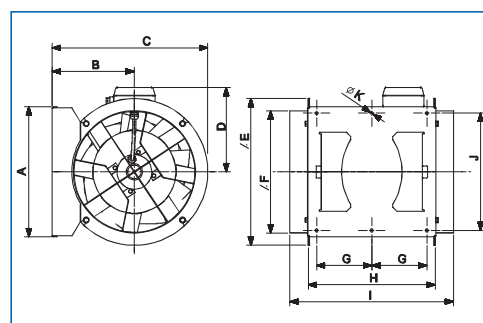

Model	X	A	Ø B	C	Ø D	E	F	G	H
TD-250/100	188	303	176	115	97	100	90	80	60
TD-350/125	188	258	176	115	123	100	90	80	60
TD-500/150	212	295	200	127	147	112	130	80	60
TD-500/160	212	275	200	127	157	112	130	80	60
TD-800/200N	232,5	302	217	141	198	124	140	100	94
TD-800/200	232,5	302	217	141	198	124	140	100	94
TD-1000/250	291	386	272	192	248	155	168	145	140
TD-1300/250	291	386	272	192	248	155	168	145	140
TD-2000/315	356	450	336	224	312	188	210	182	178

Model	A	B	C	D	Ø E	Ø F	G	H	I	J	Ø K
TD-4000/355	377	238	451	224	426	354	150	368	474	340	8.5
TD-6000/400	407	249	492	267	487	399	160	425	547	370	8.5

■ Accessories (see pages from 549 to 551)

■ Performance curves

- Q = Air volume in, m³/hr and m³/s.
- Pe = Static pressure in mmWG and Pa.
- Dry air at 20°C and 760 mmHg.

HS = High speed
LS = Low speed

- Air flow data in accordance with the following standards: UNE 100-212-89, BS 848, Part 1; AMCA 210-85 and ASHRAE 51-1985.

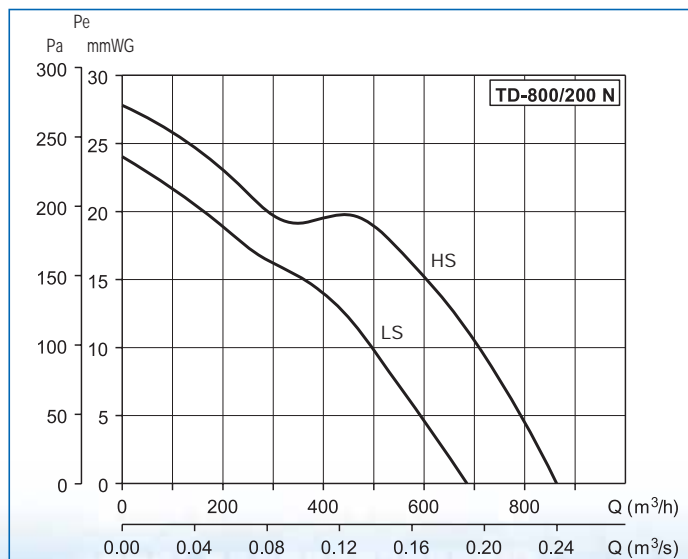
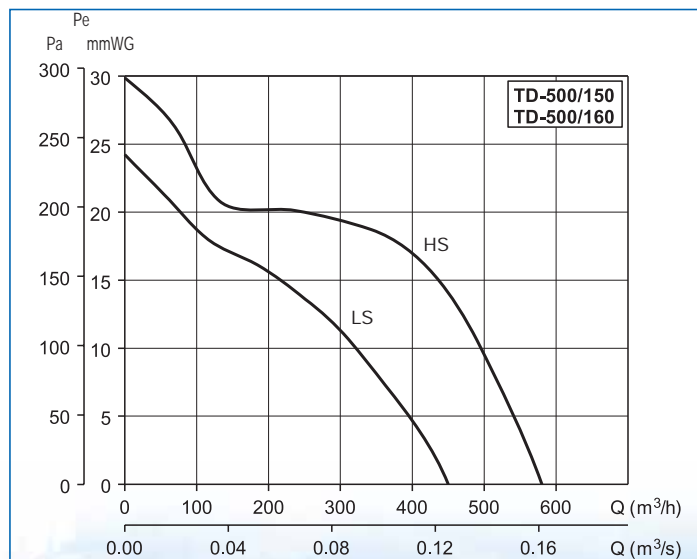
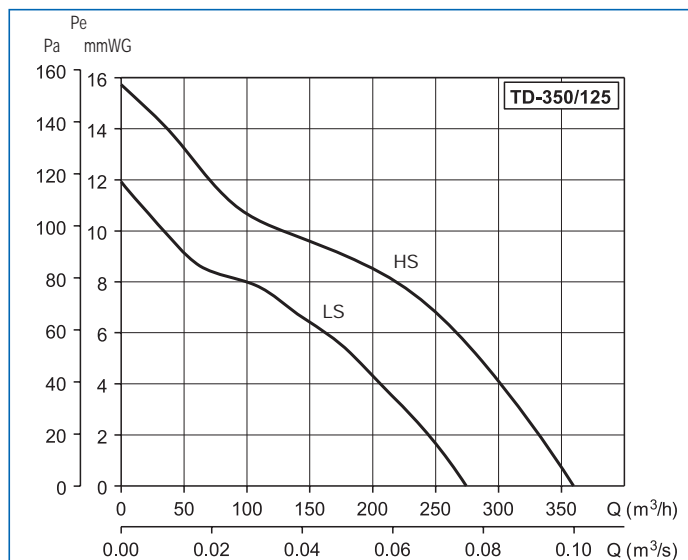
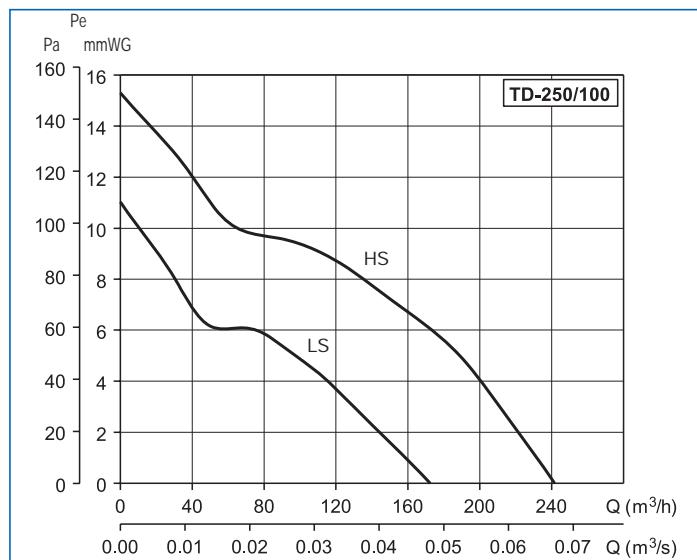
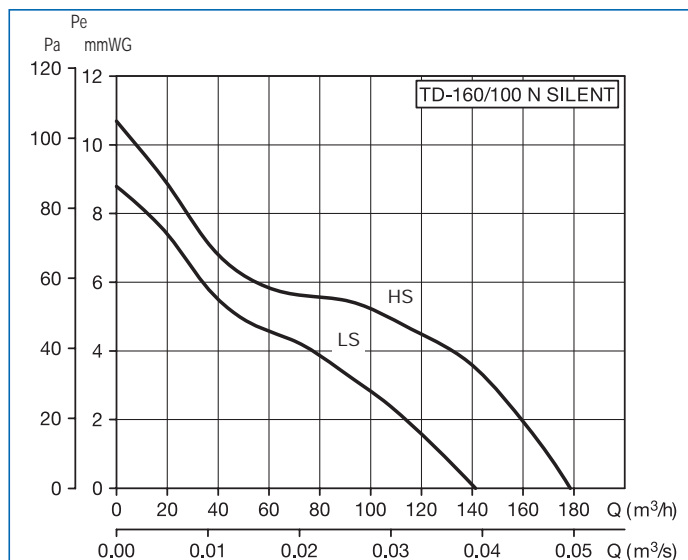

Performance curves

- Q = Air volume in, m³/hr and m³/s.
- Pe = Static pressure in mmWG and Pa.
- Dry air at 20°C and 760 mmHg.
- Air flow data in accordance with the following standards: UNE 100-212-89, BS 848, Part 1; AMCA 210-85 and ASHRAE 51-1985.

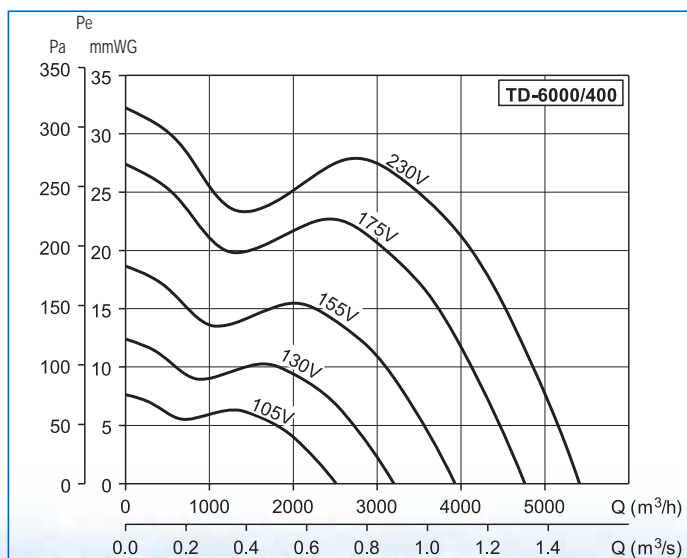
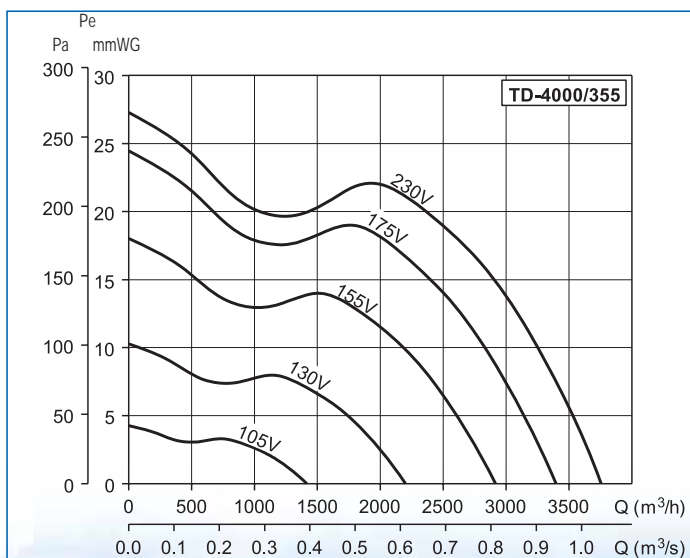
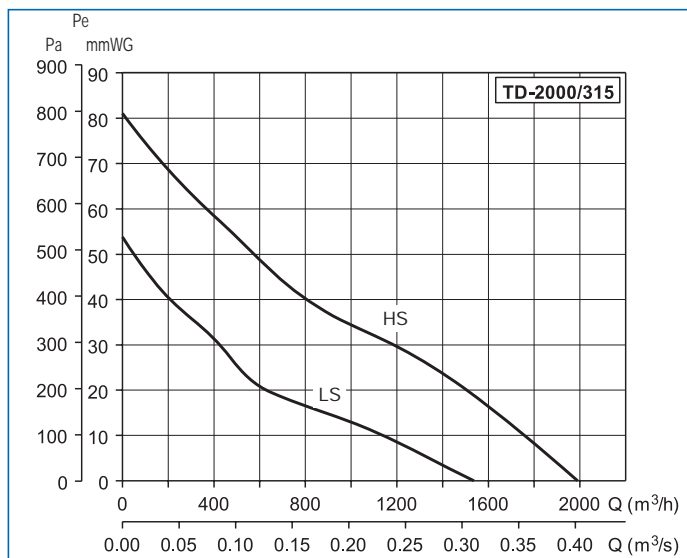
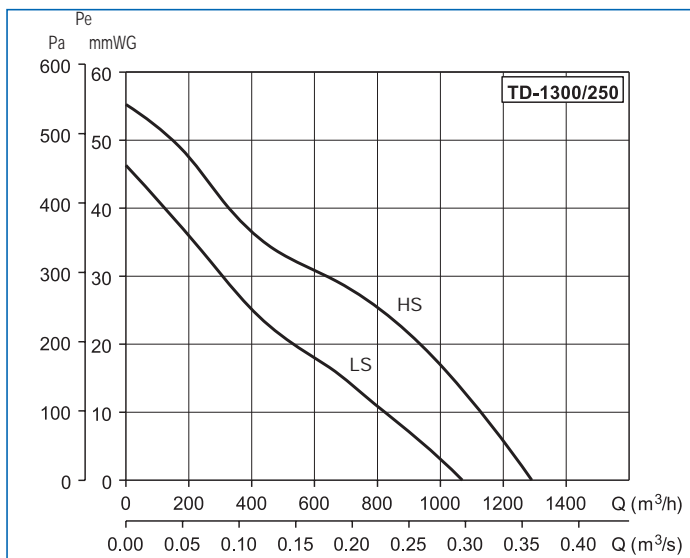
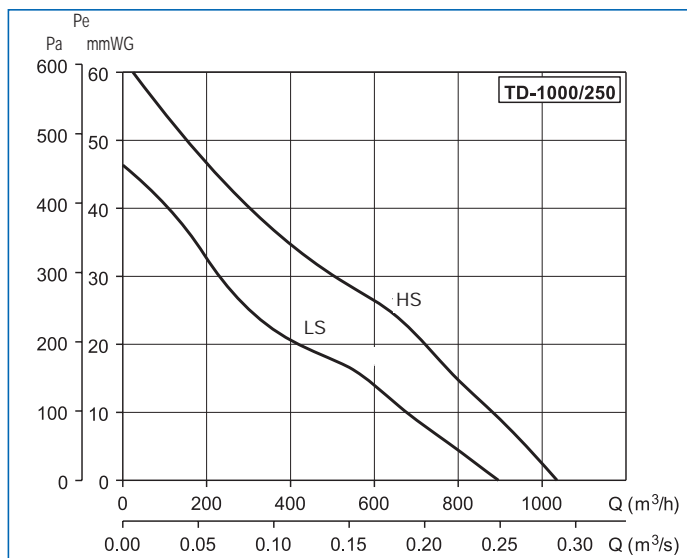
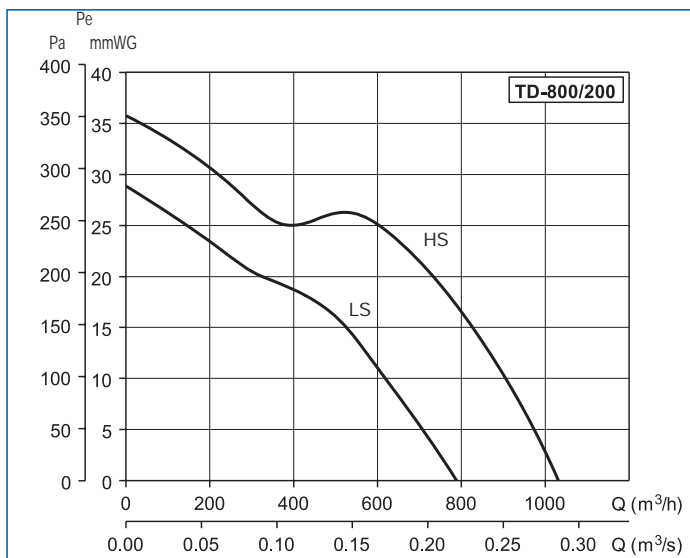

In-Line mixed flow duct fans

MIXVENT-TD Fan KITS

TD-MIXVENT

The TD ventilation kits enable the simple and fast installation of a complete ventilation system. The kits provide efficient extraction for bathrooms, toilets, washrooms and any other applications that require the removal of bad odours, stuffy and humid air.

3 kits are available:

KIT TD-160/100 N SILENT includes:

- 1 TD-160/100 N SILENT fan **NEW**
- + 4 m of flexible aluminium ducting GSA-100
- + 1 interior circular air valve BOR-100
- + 1 exterior mounted grille GR-100
- + 1 adhesive duct tape BA

KIT TD-250/100 includes:

- 1 TD-250/100 fan
- + 4 m of flexible aluminium ducting GSA-100
- + 1 interior circular air valve BOR-100
- + 1 exterior mounted grille GR-100
- + 1 adhesive duct tape BA

KIT TD-250/100T includes:

- 1 TD-250/100 T fan
- + 4 m of flexible aluminium ducting GSA
- + 1 interior circular air valve BOR-100
- + 1 exterior mounted grille GR-100
- + 1 adhesive duct tape BA

The TD-250 T extractor is fitted with an adjustable Run-On- Timer between 1 and 30 minutes, keeping the fan in operation for the selected period of time after being switched off.



In-Line duct fans

■ Installation and mounting

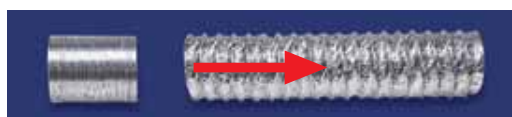
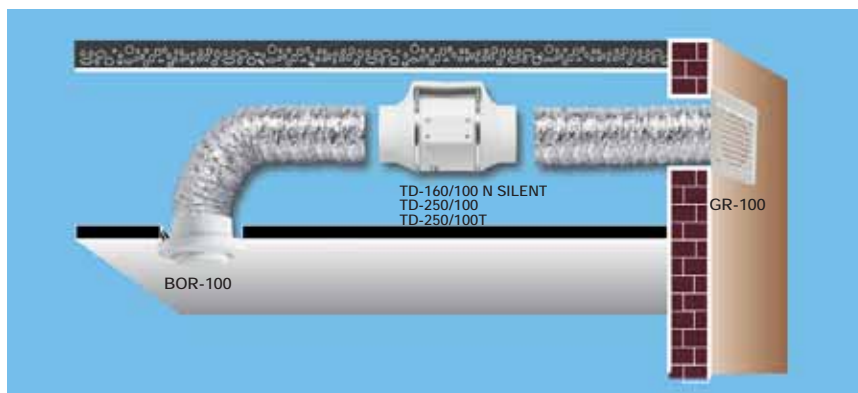

■ Accessories included in kit



GSA-100
100 mm diameter of flexible aluminium ducting



GR-100
Exterior mounted grille



BOR-100
Interior circular air valve



BA-50
Adhesive aluminium duct tape (10 m)



In-Line mixed flow duct fans MIXVENT System – COMBINATIONS

The **MIXVENT System** includes a specific range of accessories enabling the installation of different combinations of the MIXVENT -TD maintaining the concept that makes the difference: **deliver the maximum airflow using the minimum space.**



MIXVENT-TDx2 and MIXVENT-TDx3
To increase the pressure



0 025982 603070



MIXVENT-TWIN
To double the airflow



MIXVENT-TWINx2
To increase the pressure and double the airflow

MIXVENT-TDx2

The MIXVENT-TDx2 range consists of two MIXVENT-TD fans mounted in series to produce almost twice the pressure of the single TD fan. System specially recommended when the fan has the suitable airflow and when an increase of the pressure is required due to the high pressure drops.

MIXVENT-TDx2 are standard catalogue products, from 350 to 1300 model. A TDx2 can also be obtained coupling 2 TD model fans using a flange MBR (see the accessories section).



■ Technical characteristics

MIXVENT-TDx2	Speed (r.p.m.)	Maximum absorbed power (W)	Maximum current (A)	Duty at free discharge (m ³ /h)	Maximum operating temperature (°C)	Sound pressure level* (dB(A))	Weight (kg)
TDx2-350/125	2250 1900	60 44	0,26 0,20	395 320	40 40	36 31	5,4
TDx2-500/ ¹⁵⁰ / ₁₆₀	2500 1950	100 88	0,44 0,38	580 475	60 60	48 41	5,0
TDx2-800/200N	2780 2480	140 120	0,60 0,52	880 690	60 60	48 44	8,7
TDx2-800/200	2500 2000	240 200	1,00 0,90	1020 790	60 60	52 48	8,7
TDx2-1000/250	2800 2610	250 170	1,00 0,70	1020 900	60 60	57 51	18,7
TDx2-1300/250	2520 2000	360 280	1,60 1,20	1320 980	60 60	57 52	18,7

*Sound pressure level radiated at 3 m at free air conditions with rigid ducts at the inlet and at the outlet.

■ Dimensions (mm)

MIXVENT-TDx2	X	A	Ø B	C	Ø D	E	F	G	H
TDx2-350/125	188,0	417	176	115	123	100	90	253	60
TDx2-500/150	212,5	464	200	127	147	111,5	130	249	60
TDx2-500/160	212,5	444	200	127	147	111,5	130	249	60
TDx2-800/200	232,5	500	217	141	198	124	140	298	94
TDx2-1000/250	291,0	654	272	192	248	155	168	416	145
TDx2-1300/250	291,0	654	272	192	248	155	168	416	145

■ Acoustic power spectrum in dB(A) for every frequency band at the inlet and radiated, at a high speed.

AT THE INLET	63	125	250	500	1000	2000	4000	8000	RADIATED	63	125	250	500	1000	2000	4000	8000
TDx2-350/125	41	53	52	59	60	56	47	39	TDx2-350/125	39	52	52	53	53	51	39	30
TDx2-500/150	38	41	61	63	65	68	62	54	TDx2-500/150	31	38	49	45	50	59	48	35
TDx2-500/160	38	41	61	63	65	68	62	54	TDx2-500/160	31	38	49	45	50	59	48	35
TDx2-800/200N	43	48	68	70	72	70	66	58	TDx2-800/200N	32	38	54	53	58	59	50	37
TDx2-800/200	43	53	67	69	74	73	70	60	TDx2-800/200	35	42	53	52	60	63	54	39
TDx2-1000/250	41	51	64	72	78	75	68	60	TDx2-1000/250	29	40	50	52	64	63	52	49
TDx2-1300/250	43	58	70	73	81	79	72	67	TDx2-1300/250	28	42	45	53	66	65	58	53

Performance curves

- Q = Air volume in, m³/hr and m³/s.
- Pe = Static pressure in mmWG and Pa.
- Dry air at 20°C and 760 mmHg.

HS = High speed
LS = Low speed

- Air flow data in accordance with the following standards: UNE 100-212-89, BS 848, Part 1; AMCA 210-85 and ASHRAE 51-1985.

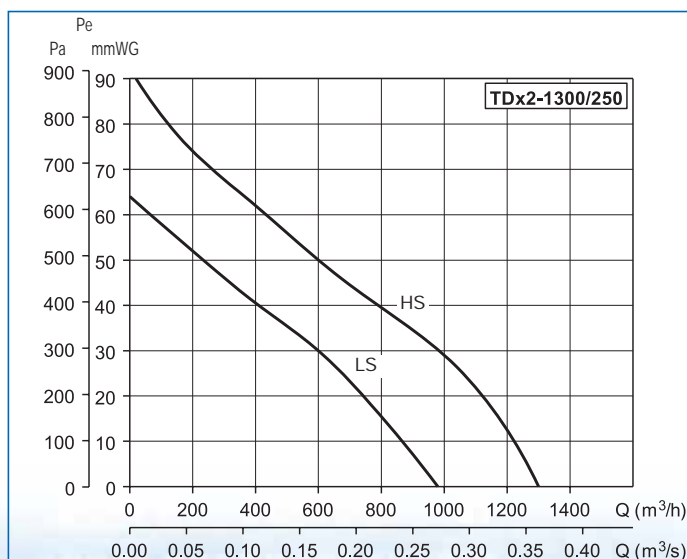
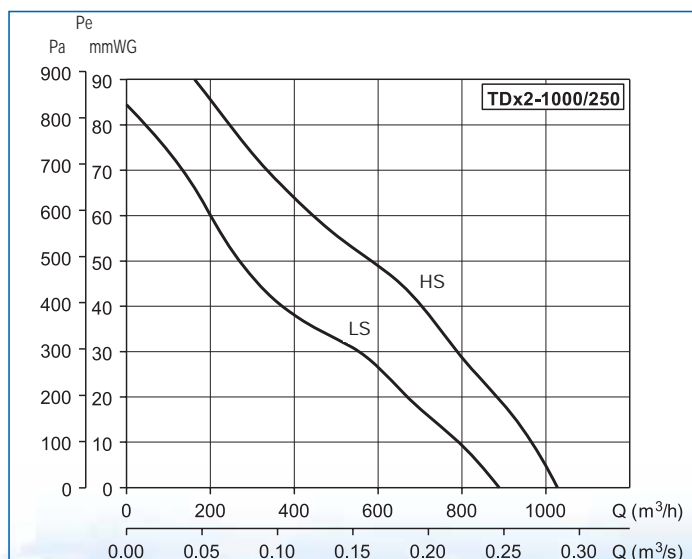
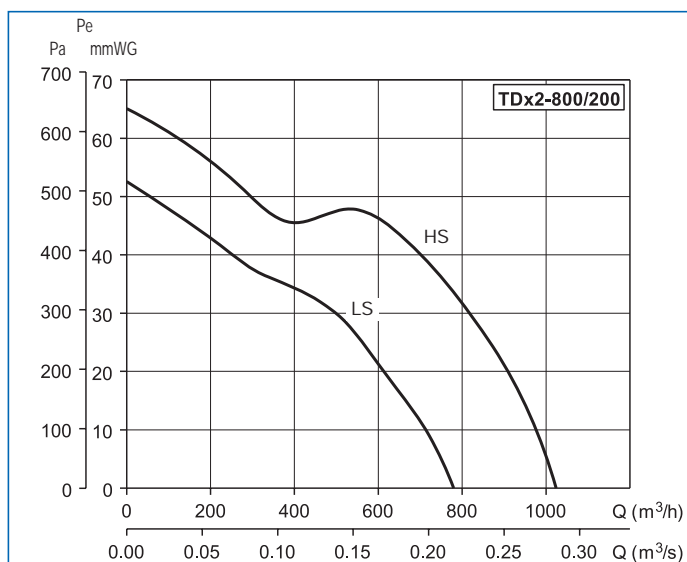
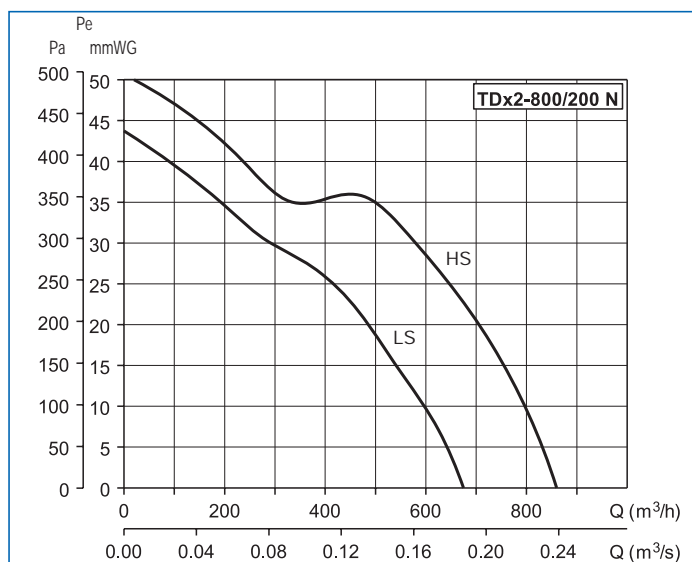
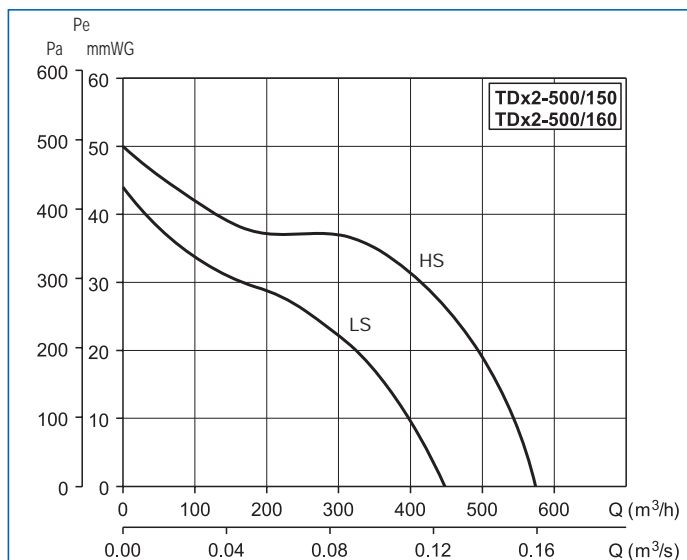
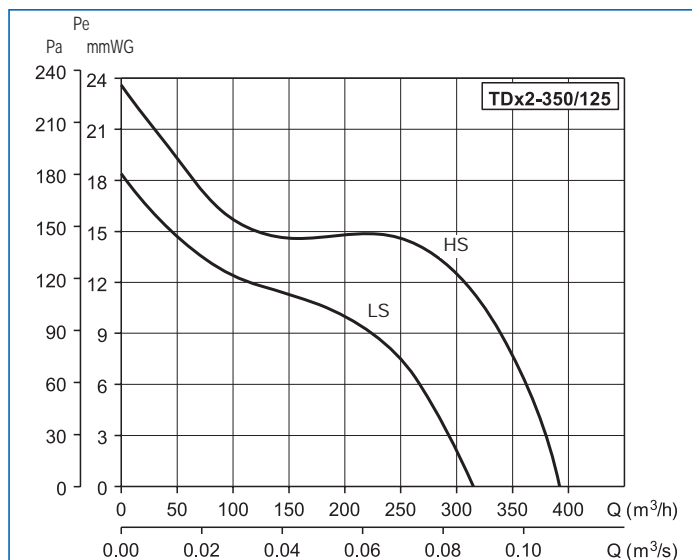

MIXVENT-TDx3

The MIXVENT-TDx3 range consists of a MIXVENT-TDx2 and MIXVENT-TD fans mounted in series using the flange MBR. System specially recommended when the fan has the suitable airflow and when an important increase of the pressure is required due to the very high pressure drop.

Technically more units could be installed in series to increase the pressure but it is recommended to carry out a study before.

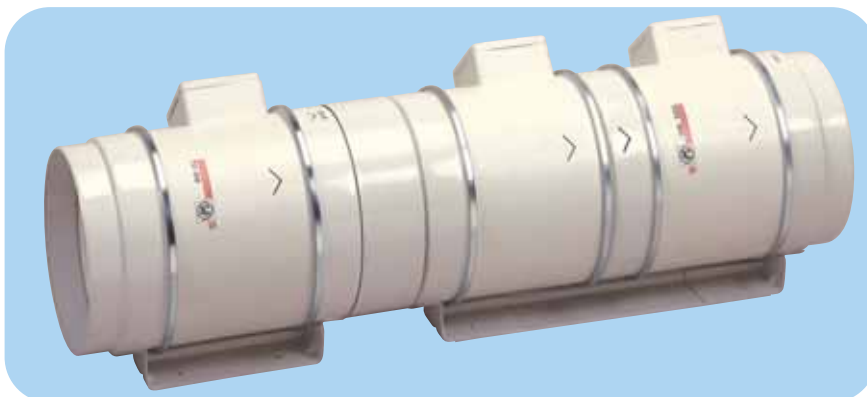

MIXVENT-TDx3 design



MIXVENT-TDx3	Composition
TDx3-350/125	TD-350/125+TDx2-350/125+MBR-350
TDx3-500/150	TD-500/150+TDx2-500/150+MBR-500/150
TDx3-500/160	TD-500/160+TDx2-500/160+MBR-500/160
TDx3-800/200	TD-800/200+TDx2-800/200+MBR-800
TDx3-1000/250	TD-1000/250+TDx2-1000/250+MBR-1000
TDx3-1300/250	TD-1300/250+TDx2-1300/250+MBR-1000



MBR flange

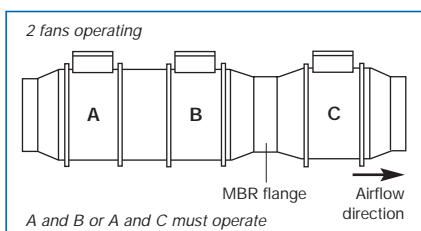
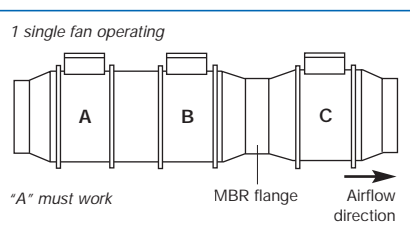

Performance curves

- Q = Air volume in, m³/hr and m³/s.
- Pe = Static pressure in mmWG and Pa.
- Dry air at 20°C and 760 mmHg.
- Air flow data in accordance with the following standards: UNE 100-212-89, BS 848, Part 1; AMCA 210-85 and ASHRAE 51-1985.

①	TD x 3-350
②	TD x 3-500
③	TD x 3-800
④	TD x 3-1000
⑤	TD x 3-1300

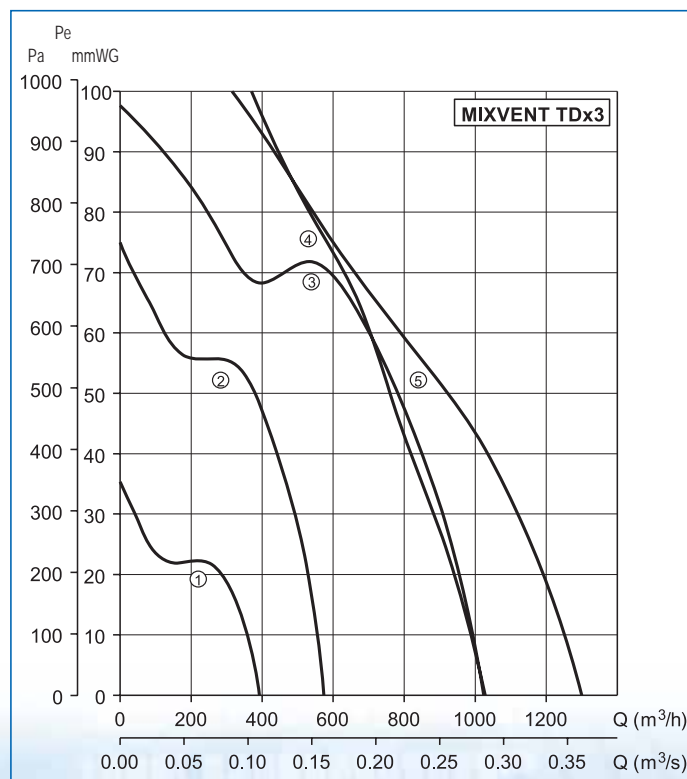

Dimensions (mm)

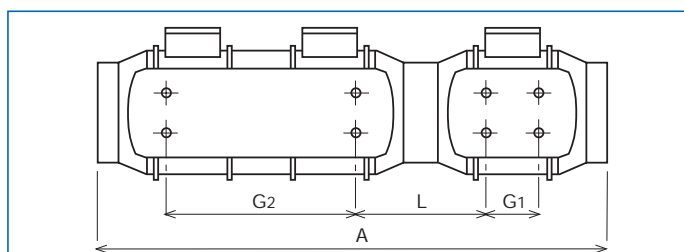

MIXVENT-TDx3	A	G ₁	G ₂	L
TD x 3-350/125	755	80	253	213
TD x 3-500/150	766	80	249	223
TD x 3-500/160	726	80	249	203
TD x 3-800/200	801	100	298	207
TD x 3-1000/250	1055	145	416	246
TD x 3-1300/250	1055	145	416	246

MIXVENT-TWIN

The MIXVENT-Twin consists of two MIXVENT-TD fans mounted in parallel using the Kit Twin Base (suitable from 250 to 2000 model).

System specially recommended when a large airflow is required (at the same pressure) within a confined space, or where a supplementary airflow is occasionally needed.

Once mounted, the whole assembly is ready to be connected to a rectangular duct using the two rectangular flanges supplied with the Kit Twin Base.

The independent operation of two MIXVENT-TD requires the use of back draft shutters at the discharge (outlet) in order to prevent the air recycling through the stationary fan.

It is also needed in installations where it is necessary to mount at the same place, two fans with the same characteristics, for extraction and supply operations.

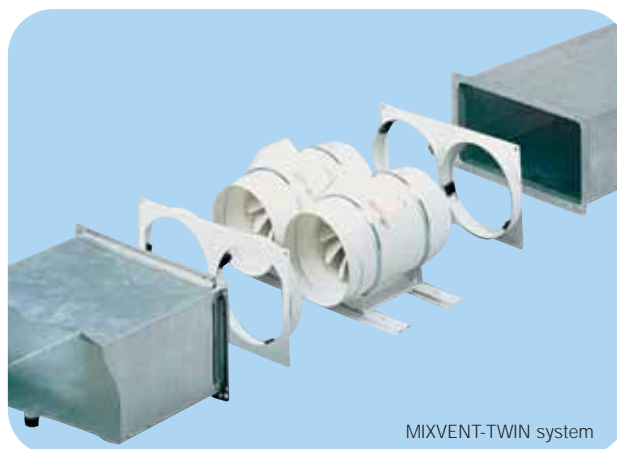

MIXVENT-TWIN system

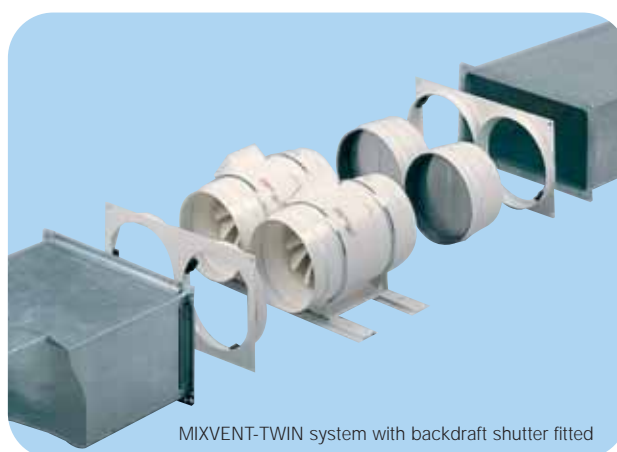

MIXVENT-TWIN system with backdraft shutter fitted

Accessories to mount MIXVENT-TWIN system

KIT TWIN BASE-250 + 2 TD -160/100

KIT TWIN BASE-250 + 2 TD 250/100

KIT TWIN BASE-350 + 2 TD -350/125

KIT TWIN BASE-500/150 + 2 TD-500/150

KIT TWIN BASE-500/160 + 2 TD-500/160

KIT TWIN BASE-800 + 2 TD-800/200

KIT TWIN BASE-1000 + 2 TD-1000/250

KIT TWIN BASE-1000 + 2 TD-1300/250

KIT TWIN BASE-2000 + 2 TD-2000/315

Backdraft shutter, see accessories page.

KIT TWIN BASE

This accessory consists of two rectangular duct couplings with standardized dimensions and two supports allowing mounting two TD or two TDx2 fans in parallel.

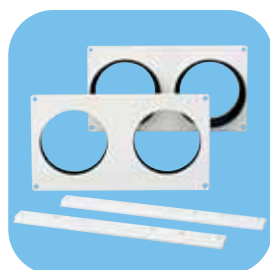

KIT TWIN BASE	Dimensions (mm)		Nominal dimensions of the rectangular duct (mm)	
	L	H	L	H
KIT TWIN BASE 250	320	180	280	140
KIT TWIN BASE 350	320	180	280	140
KIT TWIN BASE 500/150	395	220	355	180
KIT TWIN BASE 500/160	395	220	355	180
KIT TWIN BASE 800	440	240	400	200
KIT TWIN BASE 1000	540	290	500	250
KIT TWIN BASE 2000	690	355	630	315

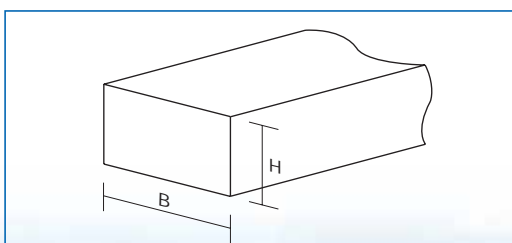

The independent operation of two MIXVENT-TD requires the use of back draft shutters at the discharge (outlet) in order to prevent the air recycling through the stationary fan.

■ Dimensions (mm)

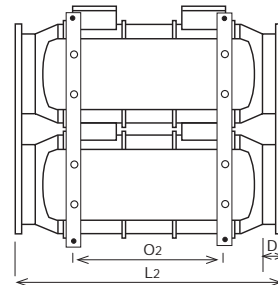
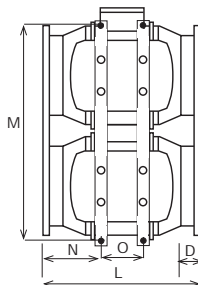
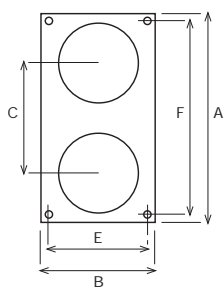

Model	A	B	C	D	E	F	L	L ₂	M	N	O	O ₂
Twin-250	320	180	184	36	160	300	305	-	375	113	80	-
Twin-350	320	180	184	33,5	160	300	305	475	333	91	80	253
Twin-500 (150)	395	220	206	37	200	375	310	481	417	110	80	249
Twin-500 (160)	395	220	206	37	200	375	290	461	417	100	80	249
Twin-800	440	240	225	37	220	420	317	509	456	103	100	298
Twin-1000	540	290	282	44	270	520	401	679	566	123	145	416
Twin-1300	540	290	282	44	270	520	401	679	566	123	145	416
Twin-2000	690	355	347	53	335	650	451	-	699	136	182	-

■ Performance curves

- Q = Air volume in, m³/hr and m³/s.
- Pe = Static pressure in mmWG and Pa.
- Dry air at 20°C and 760 mmHg.
- Air flow data in accordance with the following standards: UNE 100-212-89, BS 848, Part 1; AMCA 210-85 and ASHRAE 51-1985.

①	Twin 350	Twin x 2-350
②	Twin 500	Twin x 2-500
③	Twin 800	Twin x 2-800
④	Twin 1000	Twin x 2-1000
⑤	Twin 1300	Twin x 2-1300

■ Acoustic power spectrum in dB(A) for every frequency band at the inlet and radiated, at a high speed

AT THE INLET	63	125	250	500	1000	2000	4000	8000
TWIN-350/125	38	50	49	56	57	53	44	36
TWIN-500/150	35	38	58	60	62	65	59	51
TWIN-500/160	35	38	58	60	62	65	59	51
TWIN-800/200N	40	45	65	67	69	67	63	55
TWIN-800/200	40	50	64	66	71	70	67	57
TWIN-1000/250	38	48	61	69	75	72	65	57
TWIN-1300/250	40	55	67	70	78	76	69	64
TWIN-2000/315	44	60	69	74	80	77	70	65

RADIATED	63	125	250	500	1000	2000	4000	8000
TWIN-350/125	36	49	49	50	50	48	36	27
TWIN-500/150	28	35	46	42	47	56	45	32
TWIN-500/160	28	35	46	42	47	56	45	32
TWIN-800/200N	29	35	51	50	55	56	47	34
TWIN-800/200	32	39	50	49	57	60	51	36
TWIN-1000/250	26	37	47	49	61	60	49	46
TWIN-1300/250	25	39	42	50	63	62	55	50
TWIN-2000/315	32	44	55	58	67	66	60	56

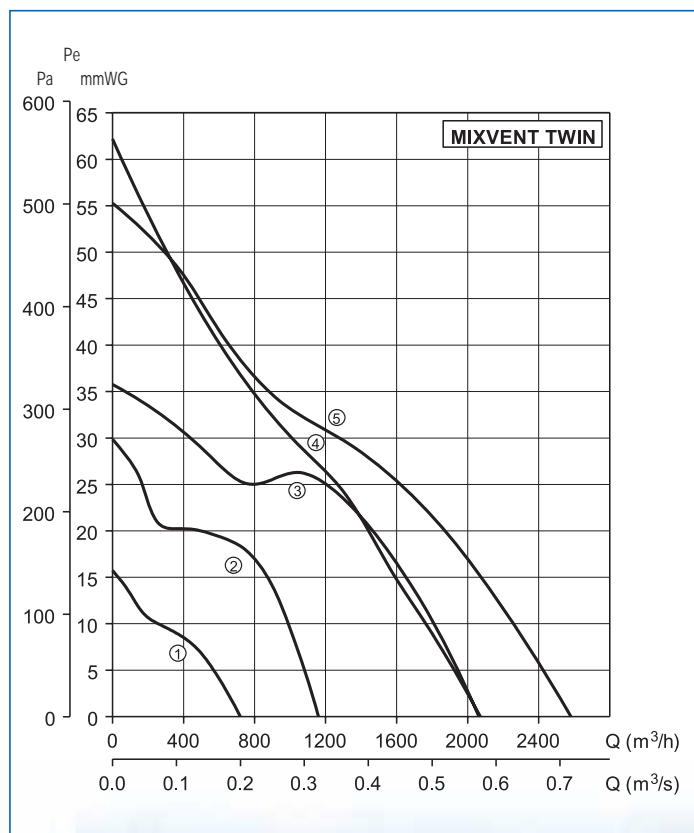

MIXVENT-TWINx2

The MIXVENT-Twinx2 consists of two MIXVENT-TDx2 fans mounted in parallel using the Kit Twin Base (suitable from 350 to 1300 model). System specially recommended when a large airflow is required (at the same pressure) within a confined space, or where a supplementary airflow is occasionally needed. Once mounted, the whole assembly is ready to be connected to a rectangular duct using the two rectangular flanges supplied with the Kit Twin Base.

The independent operation of two MIXVENT-TDx2 requires the use of back draft shutters at the discharge (outlet) in order to prevent the air recycling through the stationary fan.

■ Elements to mount MIXVENT-TWIN x 2 system

KIT TWIN BASE-350 + 2 TDx2-350/125
KIT TWIN BASE-500/150 + 2 TDx2-500/150
KIT TWIN BASE-500/160 + 2 TDx2-500/160
KIT TWIN BASE-800 + 2 TDx2-800/200
KIT TWIN BASE-1000 + 2 TDx2-1000/250
KIT TWIN BASE-1000 + 2 TDx2-1300/250

Backdraft shutter, see accessories page.

■ KIT TWIN BASE

This accessory consists of two rectangular duct couplings with standardized dimensions and two supports allowing mounting two TD or two TDx2 fans in parallel.

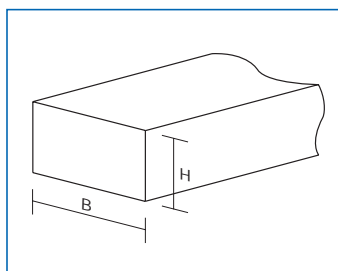
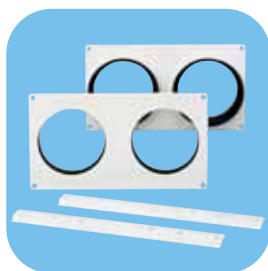

KIT TWIN BASE	Dimensions (mm)		Nominal dimensions of the rectangular duct (mm)	
	L	H	L	H
KIT TWIN BASE 250	320	180	280	140
KIT TWIN BASE 350	320	180	280	140
KIT TWIN BASE 500/150	395	220	355	180
KIT TWIN BASE 500/160	395	220	355	180
KIT TWIN BASE 800	440	240	400	200
KIT TWIN BASE 1000	540	290	500	250
KIT TWIN BASE 2000	690	355	630	315

Due to the isolated operation of TD models, backdraft shutters mounted at the outlet of TD fans are required in order to avoid the backdraft of air when the fan is not operating.

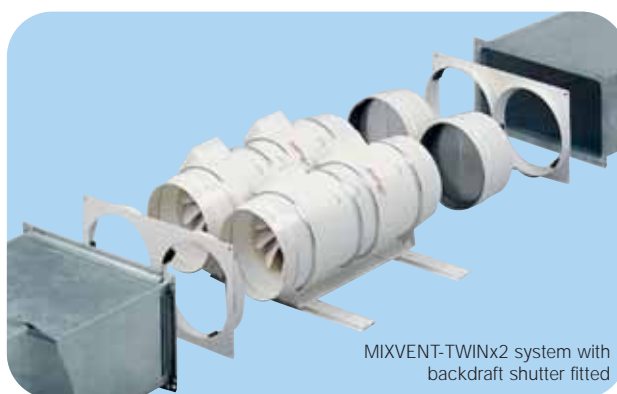
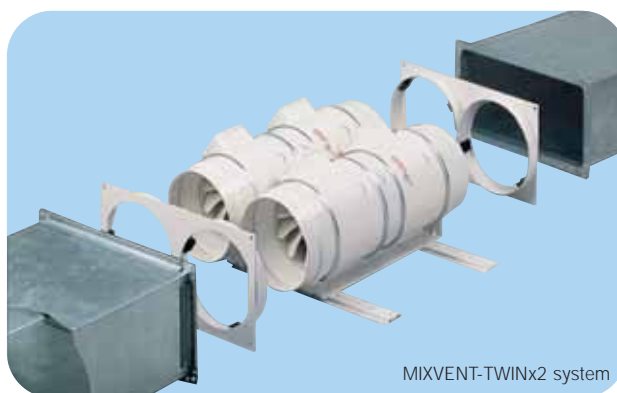

■ Performance curves

- Q = Air volume in, m³/hr and m³/s.
- Pe = Static pressure in mmWG and Pa.
- Dry air at 20°C and 760 mmHg.
- Air flow data in accordance with the following standards: UNE 100-212-89, BS 848, Part 1; AMCA 210-85 and ASHRAE 51-1985.

①	Twin 350	Twin x 2-350
②	Twin 500	Twin x 2-500
③	Twin 800	Twin x 2-800
④	Twin 1000	Twin x 2-1000
⑤	Twin 1300	Twin x 2-1300

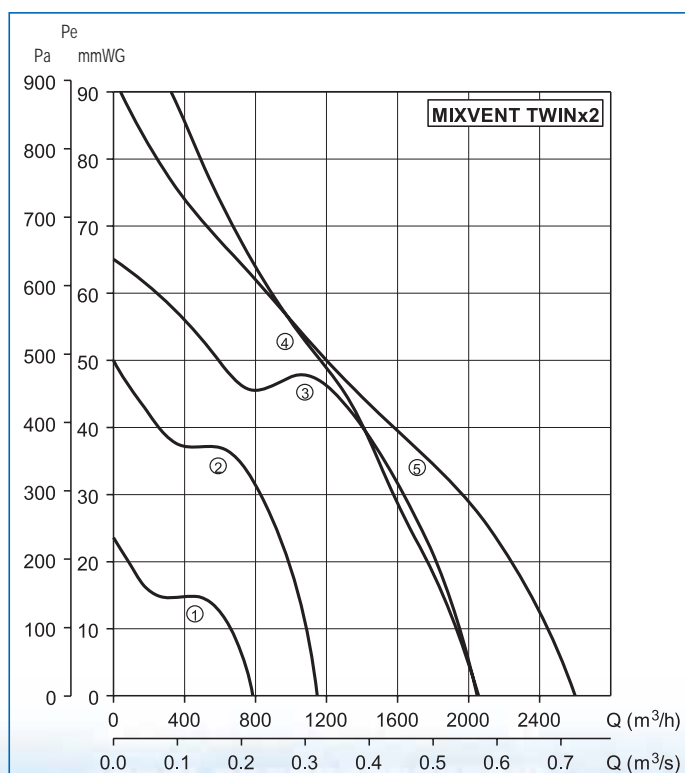



TD-ECOWATT Series

NEW

TD ECOWATT

In-Line duct fans



ENERGY EFFICIENT

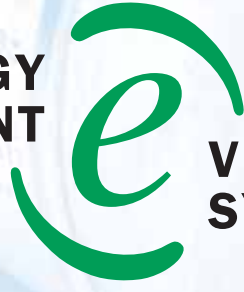

VENTILATION SYSTEM

Range of Low Profile Mixed flow fans with ball bearings and brushless DC motors, of high efficiency and low consumption.

Manufactured in plastic, removable fan body, and rated as standard 90/260V-50/60Hz, IP44, speed controllable from 10% to 100%.

Specially suitable for any kind of ventilation application, where the fan must operate continuously allowing a very important energy saving, or on those requiring a Demand Controlled Ventilation System involving the use of other sensors or controls

Low profile

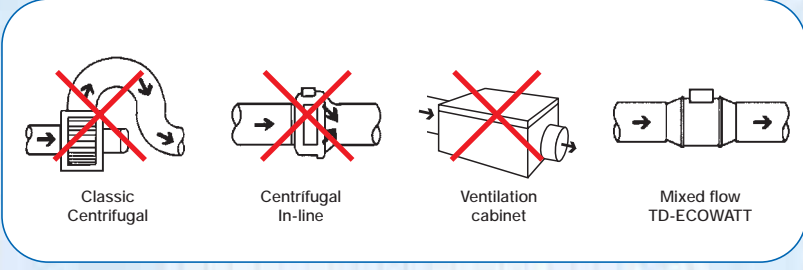

The low profile of the TD-ECOWATT fans makes them the most effective solution for installations where the space of installation is limited such as false ceilings.

Easy to mount



Fix the support bracket



Place the impeller and motor assembly



Carry out the wiring connections



Connect the ducts

Easy maintenance



The unique design of the support bracket allows the motor and impeller assembly to be fitted or removed without dismantling the adjacent ducting

Continuous current motor



Electronics totally integrated in the product



Continuous current brushless motor, high performance and **low consumption**, adjustable in lineal form

Flexible mounting position

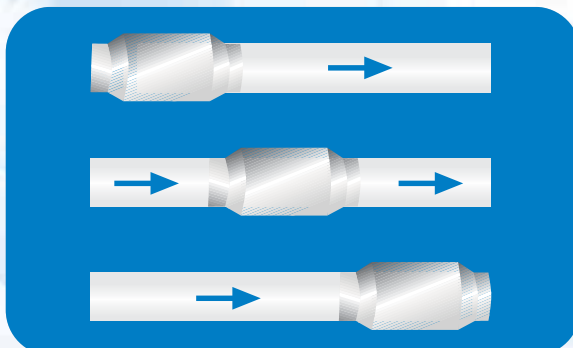

Can be mounted at any place of the air duct

■ Design characteristics

	160	250	350	500	800
Plastic housing	•	•	•	•	•
Plastic impeller	•	•	•	•	•
Insulation Class	II	II	II	II	II
Non self resetable thermal protection	•	•	•	•	•
Ball bearings	•	•	•	•	•

■ Technical characteristics

	Speed (r.p.m.)	Maximum power absorbed (W)	Maximum absorbed current (A)	Airflow at free discharge (m ³ /h)	Maximum operating temperature (°C)	Sound pressure level* (dB(A))	Ø Duct (mm)	Weight (kg)
TD-MIXVENT								
TD-160/100 ECOWATT	2650	10	0,07	190	60	34	100	1,4
TD-250/100 ECOWATT	2400	22	0,17	275	60	35	100	2,0
TD-350/125 ECOWATT	2420	22	0,17	360	60	34	125	2,0
TD-500/150 ECOWATT	2600	48	0,35	580	60	36	150	2,7
TD-800/200 ECOWATT	2360	105	0,75	1030	60	38	200	4,9

■ Sound characteristics

Sound Power Spectrum in dB(A), per band of frequency, at inlet, outlet or radiated, for working points low (B), medium(M) or high (A) on every fan curve. Tests made according to SO 13347-3 004.

TD-160/100 ECOWATT		63	125	250	500	1.000	2.000	4.000	8.000	GLOBAL
INLET	B	30	31	43	50	58	58	44	34	61
	M	31	32	44	51	56	57	42	33	60
	A	36	37	47	54	56	59	41	31	62
OUTLET	B	29	29	40	51	56	56	45	34	60
	M	30	30	39	52	56	56	43	33	60
	A	32	36	40	54	55	53	43	33	59
RADIATED	B	24	31	43	47	46	52	38	25	54
	M	25	32	44	48	44	51	36	24	54
	A	30	37	47	51	44	53	35	22	56

TD-250/100 ECOWATT		63	125	250	500	1.000	2.000	4.000	8.000	GLOBAL
INLET	B	26	32	44	57	55	53	45	36	60
	M	27	32	46	55	55	53	44	36	60
	A	28	33	46	54	55	53	44	36	59
OUTLET	B	32	33	45	56	53	53	44	36	59
	M	29	32	47	56	52	52	43	35	59
	A	29	33	49	53	50	51	41	33	57
RADIATED	B	23	29	44	50	50	50	39	29	55
	M	24	29	46	48	50	50	38	29	55
	A	25	30	46	47	50	50	38	29	55

TD-350/125 ECOWATT		63	125	250	500	1.000	2.000	4.000	8.000	GLOBAL
INLET	B	24	29	44	52	55	54	44	33	59
	M	28	28	44	52	53	52	44	35	58
	A	29	35	50	53	55	55	45	35	60
OUTLET	B	32	33	46	56	55	54	43	34	60
	M	29	30	45	55	53	52	43	34	59
	A	31	35	50	56	52	52	42	33	59
RADIATED	B	18	20	44	42	48	50	36	23	53
	M	22	19	44	42	46	48	36	25	52
	A	23	26	50	43	48	51	37	25	55

TD-500/150 ECOWATT		63	125	250	500	1.000	2.000	4.000	8.000	GLOBAL
INLET	B	26	36	53	56	58	64	58	50	67
	M	26	34	50	55	57	61	55	48	64
	A	26	37	53	58	59	61	56	48	65
OUTLET	B	34	36	56	61	62	62	57	50	67
	M	29	34	51	60	61	59	55	48	66
	A	31	34	55	65	62	59	56	49	68
RADIATED	B	18	24	51	37	45	55	43	35	57
	M	18	22	48	36	44	52	40	33	54
	A	18	25	51	39	46	52	41	33	55

TD-800/200 ECOWATT		63	125	250	500	1.000	2.000	4.000	8.000	GLOBAL
INLET	B	27	35	51	55	66	66	61	51	70
	M	26	33	49	54	65	63	59	49	68
	A	36	47	63	64	66	63	59	51	71
OUTLET	B	48	47	51	61	65	67	62	50	71
	M	40	39	49	62	65	65	59	48	69
	A	36	43	61	68	67	65	60	51	72
RADIATED	B	27	22	41	36	54	56	48	33	59
	M	26	20	39	35	53	53	46	31	57
	A	36	34	53	45	54	53	46	33	59

■ Dimensions (mm)

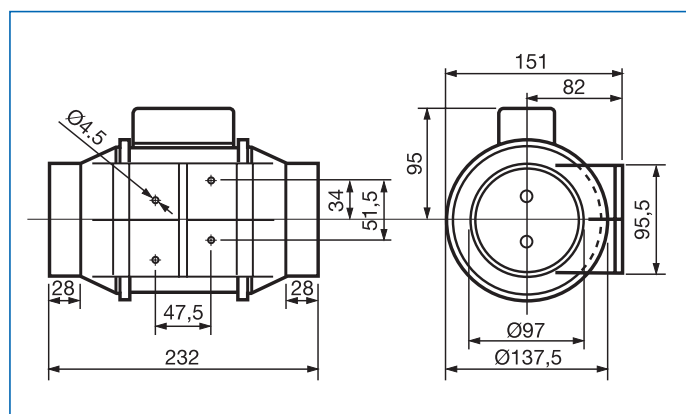

TD-160/100 ECOWATT

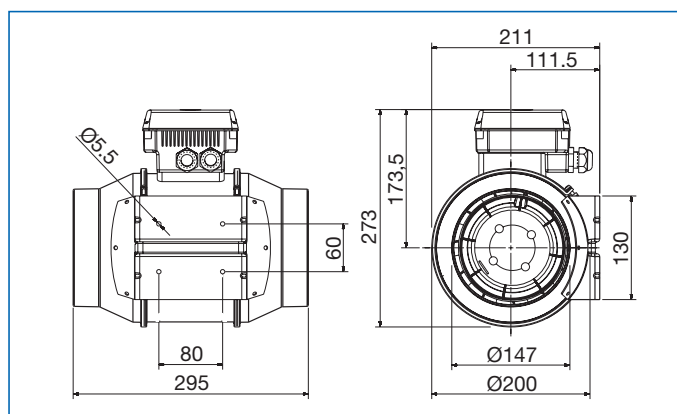

TD-500/150 ECOWATT

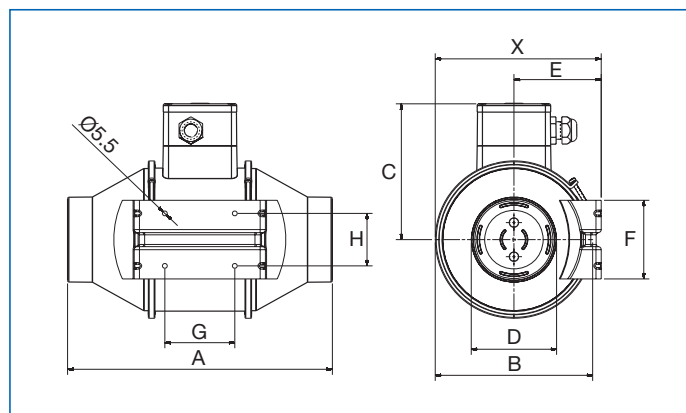

TD-250/100 and TD-350/125 ECOWATT

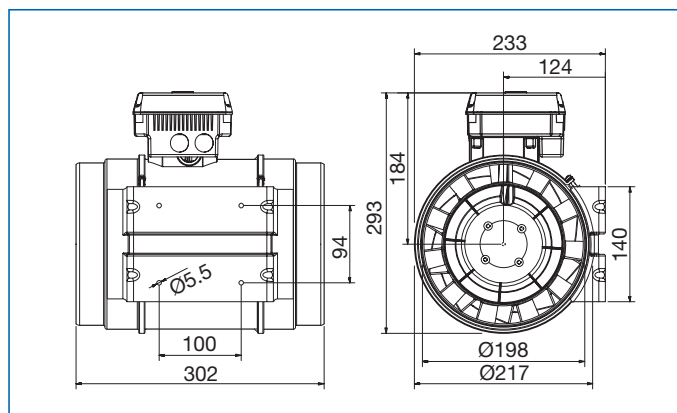

TD-800/200 ECOWATT

Model	X	A	ØB	C	ØD	E	F	G	H
TD-250/100 ECOWATT	188	303	176	156	97	100	90	80	60
TD-350/125 ECOWATT	188	258	176	156	123	100	90	80	60

Characteristic curves

- Q = Air volume in, m³/hr and m³/s.
- Pe = Static pressure in mmWG and Pa.
- Dry air at 20°C and 760 mmHg.
- Air flow data in accordance with the following standards: UNE 100-212-89, BS 848, Part 1; AMCA 210-85 and ASHRAE 51-1985.

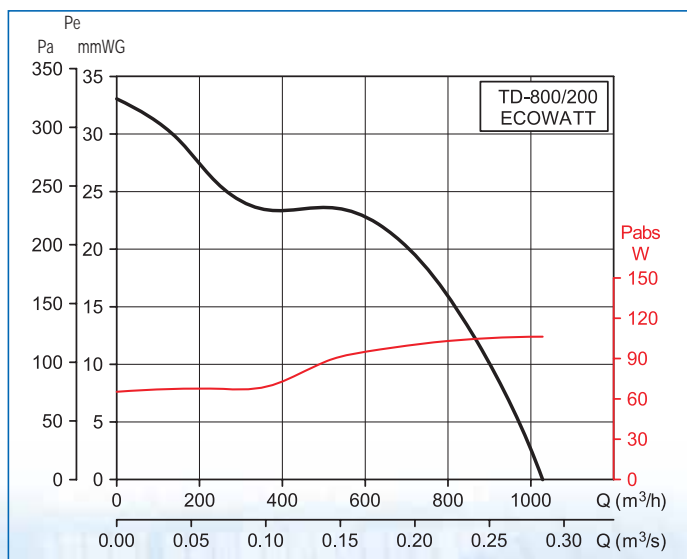
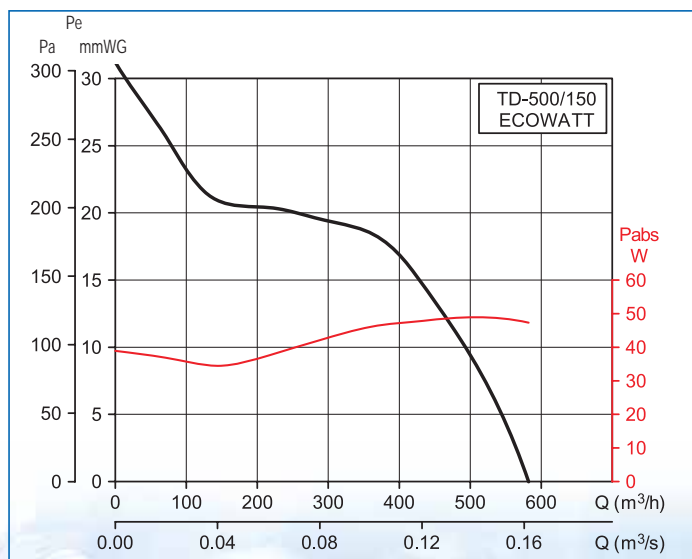
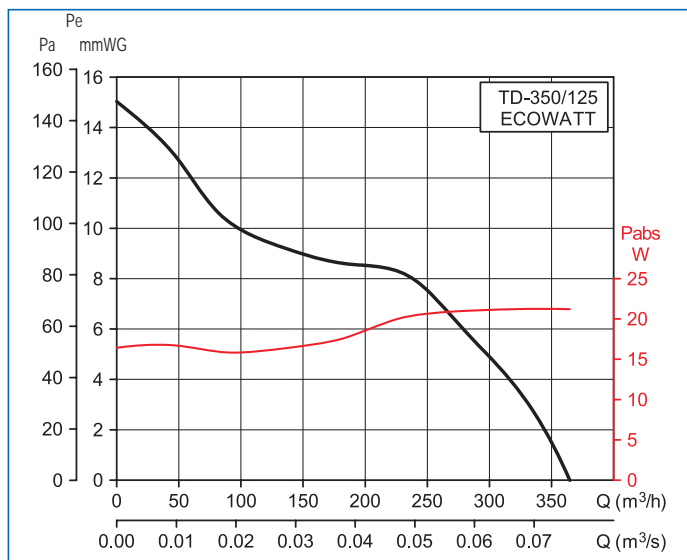
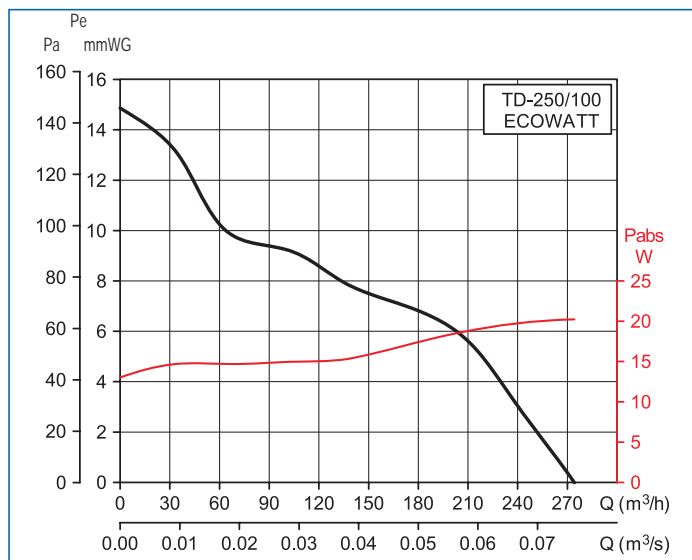
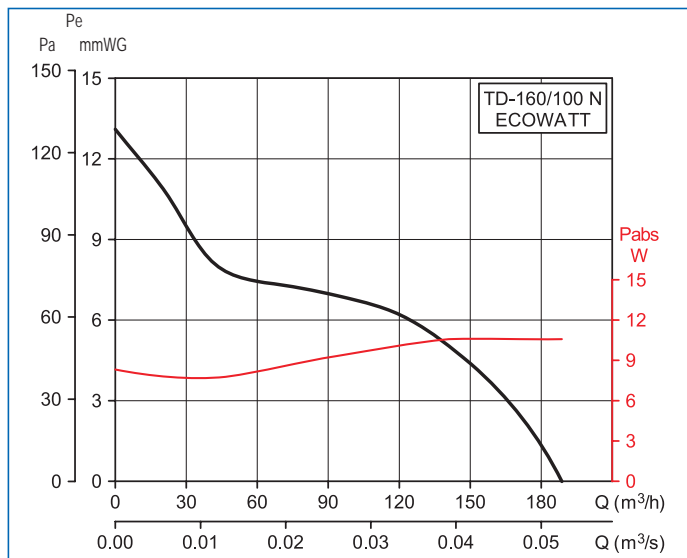

MIXVENT HEATING System (MIXVENT-TD + MBE heater battery)

The MIXVENT heating system offers the most economic solution for the heating of fresh air supply systems.

The MIXVENT HEATING system consists on a MBE electric heater battery installed on the discharge side of the MIXVENT-TD fan.

The minimum air velocity through the heater batteries must be 2 m/s.

The batteries incorporate:

- Insulated element rods.
- Automatic overheat thermostat wired in series with an additional safety overheat manual reset thermostat (RESET). Units are available for single phase (models 100, 125 and 160) or three phase (other models) electrical supply connection, with a circuit protection supplied on 230V single phase.
- Connection box IP43.

A range of duct or ambient temperature sensors and controllers accessories to accompany the electrical heater battery are available. These controller accessories modulate the heater output as a function of the required environmental temperature. With this system it is possible to achieve temperature rise up to 50° on the supply air.



TD-MIXVENT

MBE Electrical heater battery



TD-MIXVENT	MBE battery type	Battery power (W)	Batteries supply	Minimum airflow (m³/s)	Speed controller type
250/100	MBE-100/04B	400	1/230	60	PULSER
350/125	MBE-125/12B	1200	1/230	90	PULSER
500/160	MBE-160/21B	2100	1/230	150	PULSER
800/200	MBE-200/50T	5000	2/400	230	PULSER
1000-1300/250	MBE-250/60T	6000	2/400	350	PULSER
2000/315	MBE-315/90T	9000	3/400	560	TTC-2000
4000/355	MBE-355/90T	9000	3/400	710	TTC-2000
6000/400	MBE-400/120T	12000	3/400	900	TTC-2000



In those installations where MIXVENT HEATING system is required it is convenient to use filter boxes MFL to protect the electrical batteries from the debris.

SELECTION EXAMPLE

DATA:

- Airflow: 700 m³/h (Q)
- Input air temperature: +5 °C
- Required output temperature: +27 °C

REQUIRED HEAT POWER:

$$\begin{aligned}
 P &= Q \times 0,36 \times \Delta T \\
 &= 700 \times 0,36 \times 22 \\
 &= 5544 \text{ W}
 \end{aligned}$$

BATTERY ELECTION

Or: MBE-200/50T
Or: MBE-250/60T

Final election will depend of:

- Total pressure drop
- Desired sound level
- Available space

Difference of temperature between external and internal air ΔT (°C)

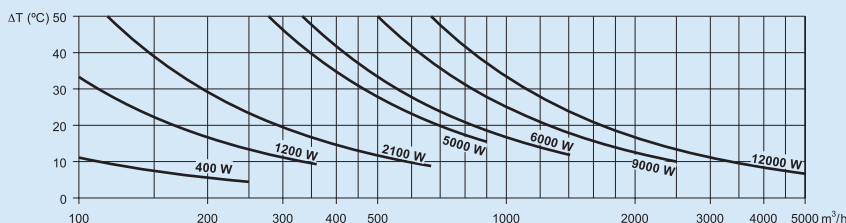

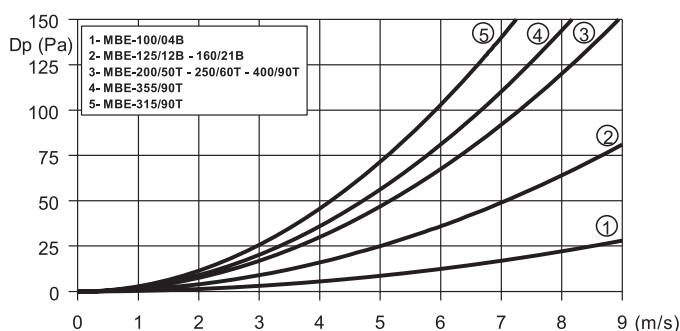
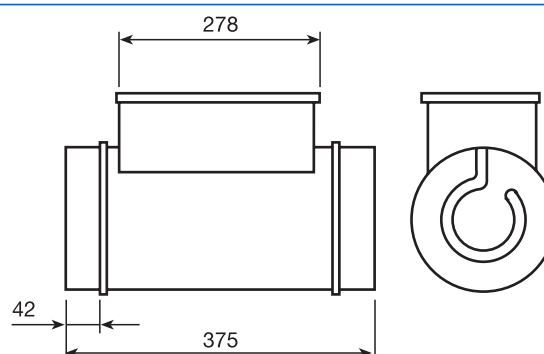
Battery pressure drop
 Δp (Pa)

Dimensions (mm)

MBE heater batteries accessories

 Dimensions LxAxH (mm):
 92x45x150

PULSER controller

Electronic controller to regulate the heat output for single phase or two phase (200 - 415 V) electric heater battery in order to maintain a constant pre-selected temperature. Depending on the selected temperature, the controller pulses the entire power output and uses a time-proportional control to maintain that temperature. PULSER incorporates a built-in temperature sensor and can be installed directly in the room to heat. External temperature sensors can be also connected.

 Dimensions LxAxH (mm):
 160x140x280

TTC-2000 controller

Electronic controller to regulate the heat output for three phase electrical heater batteries up to 16.5kW in order to maintain a constant pre-selected temperature. Depending on the selected temperature, the controller pulses the entire power output and uses a time-proportional control to maintain that temperature. TTC-2000 is designed to be mounted within a main electrical board and has to be connected to a temperature sensor placed in the room to heat or in the warm air supply ducting.

 Dimensions LxAxH (mm):
 70x30x70

Room temperature sensor TG-R530

To place in the room to heat:

- NTC type with linear scale
- Operating temperature: 0 -30°C
- IP-20

Suitable for controller type TTC-2000.

Duct temperature sensor TG-K330

Temperature sensor to place in the warm air supply ducting.

- NTC type with linear scale
- Operating temperature: 0 -30°C
- IP-20

Suitable for controllers type PULSER and TTC-2000.

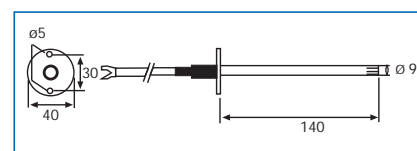

MIXVENT FILTER System (TD-MIXVENT + Filtration box MFL)

The MIXVENT HEATING system consists on a MFL filtration box installed on the inlet side of the MIXVENT-TD fan and are used when the installation requires supplying filtered clean air. MFL filtration boxes are of EU4 grade filtration and are designed for direct connection with standard circular ducting.

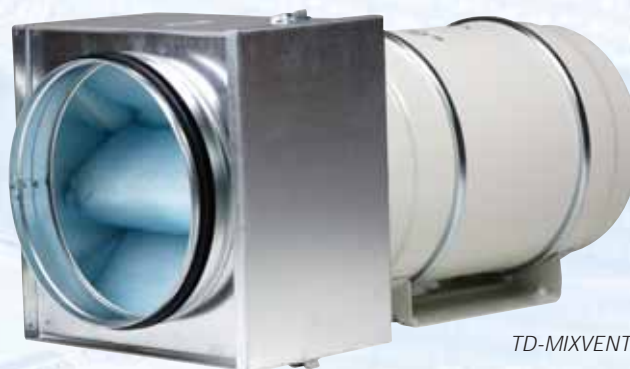

Filter box MFL

TD-MIXVENT



A usual application of MFL filtration boxes is to protect the electrical heater batteries from the dirt, in installations where MIXVENT HEATING system is used.



0 026182 603075



The MFL filtration boxes are supplied with a cover easily removable to replace the filter.

Dimensions (mm)

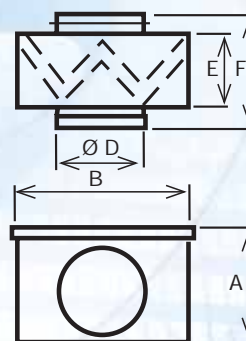

Model	A	B	D	E	F
MFL-100	200	200	100	160	196
MFL-125	200	200	125	160	196
MFL-160	200	200	160	154	196
MFL-200	243	244	200	154	202
MFL-250	293	294	250	154	206
MFL-315	342	343	315	154	206
MFL-355	447	448	355	154	254
MFL-400	447	448	400	154	254

Pressure drop of the filter boxes Δp (Pa)

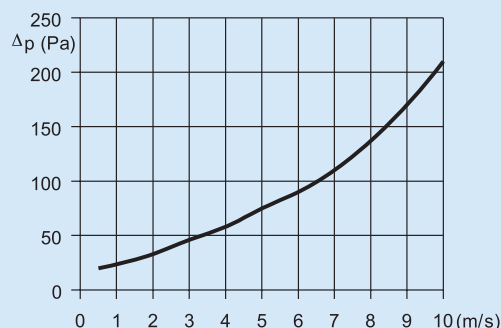

TD-MIXVENT Installation accessories

■ Specific accessories for TD Series



MCA

Back-draft shutters mounted at the outlet of the fans, to prevent external air entry and to limit heat leakage, when the fan are not in use. To apply with TD, TDx2, TDx3 and TWIN models.

Model MCA/JCA	Type of TD - TDx2 - TDx3 - TWIN
MCA - 250	160/100N - 250/100
MCA - 350	350/125
MCA - 500/150	500/150
MCA - 500/160	500/160
MCA - 800	800/200 - 800/200N
MCA - 1000	1000/250 - 1300/250
MCA - 2000	2000/315
MCA - 4000	4000/355
MCA - 6000	6000/400

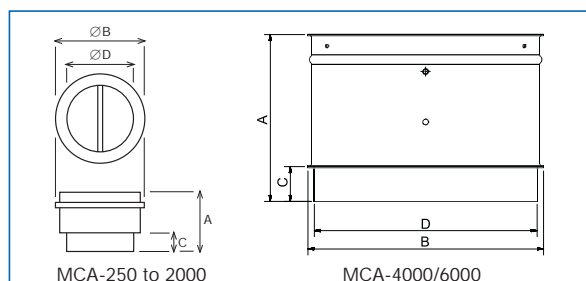

Model MCA	A	Ø B	C	Ø D
MCA - 250	107	111	31,5	94,5
MCA - 350	107	136	31,5	119,5
MCA - 500/150	121	163,5	35	147
MCA - 500/160	121	173,5	35	157
MCA - 800	131,5	214	35	197,5
MCA - 1000	164	264,5	42	248
MCA - 2000	205	330	50	312
MCA - 4000	265	374	55	354
MCA - 6000	307	419	65	399



MAR

Rectangular Duct Adapters enable TD, TDx2 and TDx3 to be connected to rectangular ducting.

Model MAR	Type of TD-TDx2-TDx3	Nominal dim. of ducting L x H
MAR - 250	160/100N - 250/100	224 x 140
MAR - 350	350/125	224 x 140
MAR - 500/150	500/150	280 x 180
MAR - 500/160	500/160	280 x 180
MAR - 800	800/200-800/200N	315 x 200
MAR - 1000	1000/250-1300/250	400 x 250
MAR - 2000	2000/315	500 X 315

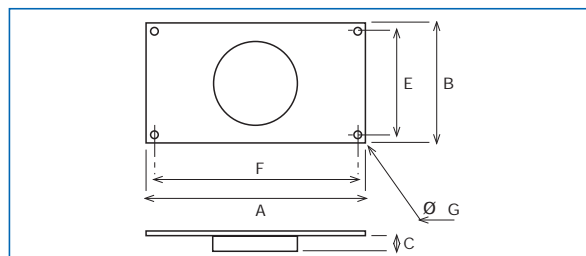

Model MAR	A	B	C	E	F	Ø G
MAR - 250	264	180	33,3	160	244	9
MAR - 350	264	180	33,5	160	244	9
MAR - 500/150	320	220	37	200	300	9
MAR - 500/160	320	220	37	200	300	9
MAR - 800	355	240	37	220	335	9
MAR - 1000	440	290	42	270	420	9
MAR - 2000	540	355	52	355	520	9



MRJ

Grilles mounted at the inlet or outlet of the fan, to prevent the entry of any foreign objects that could damage the fan. To apply with TD, TD x 2, TD x 3 and TWIN models.

Model MRJ	Type of TD - TDx2 - TDx3 - TWIN
MRJ - 250	160/100N - 250/100
MRJ - 350	350/125
MRJ - 500/150	500/150
MRJ - 500/160	500/160
MRJ - 800	800/200 - 800/200N
MRJ - 1000	1000/250 - 1300/250
MRJ - 2000	2000/315
MRJ - 4000	4000/355
MRJ - 6000	6000/400



MBR
Flanges allowing the coupling of TD fans in series.

Model MBR	Ø of the duct
MBR-350	125
MBR-500/150	150
MBR-500/160	160
MBR-800	200
MBR-1000	250



KIT TWIN BASE
This accessory consists of two rectangular duct couplings with standardized dimensions and two supports allowing mounting two TD or two TDx2 fans in parallel.

KIT TWIN BASE	Dimensions (mm)		Nominal dim. of rectangular duct (mm)	
	L	H	L	H
KIT TWIN BASE 250	320	180	280	140
KIT TWIN BASE 350	320	180	280	140
KIT TWIN BASE 500/150	395	220	355	180
KIT TWIN BASE 500/160	395	220	355	180
KIT TWIN BASE 800	440	240	400	200
KIT TWIN BASE 1000	540	290	500	250
KIT TWIN BASE 2000	690	355	630	315

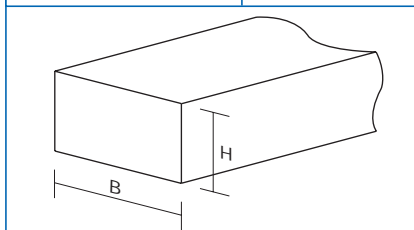

Due to the independent operation of TD models, backdraft shutters mounted at the outlet of TD fans are required in order to avoid the backdraft of air when the fan is disconnected.



SIL
Sound attenuators

Model	ØA (mm)	ØB (mm)	C (mm)	D (mm)	Attenuation in dB							
					63	125	250	500	1000	2000	4000	8000
SIL 125	125	250	700	900	2	5	13	21	37	37	31	9
SIL 160	160	250	700	900	2	9	14	23	25	16	11	6
SIL 200	200	315	700	900	2	8	11	23	25	17	9	4
SIL 250	250	355	700	900	2	6	10	19	25	16	7	3
SIL 315	315	400	700	860	2	2,2	3,3	9	21,2	7,6	4,1	5,5
SIL 355	355	450	700	860	3,7	4,1	6,7	13,2	14,3	3,4	8,1	7
SIL 400	400	500	700	860	1,8	3,1	4	9,5	13,7	5,6	0,4	5,9

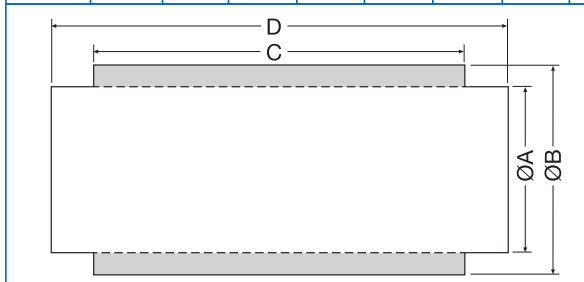

SIL sound attenuator mounted together with a TD-MIXVENT, a filter box MFL and a heat electrical battery MBE

■ General installation accessories



GSA
Flexible aluminium ducting



GSI
Flexible acoustic ducting



CX
Worm drive clips



PER-W
Outdoor plastic louvre shutters



BOC
Circular air valves



RED
Reducer



MRT
Joining pieces



CT
Roof terminal kits



GRA
Aluminium external grilles



GRI
Internal extract grilles

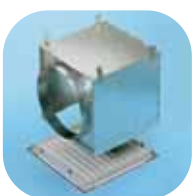

RP
Terminal connectors for GRI internal grilles



GCI
Interior circular grilles

■ Electrical accessories



REGUL 2
2 Speed switch



REB
Single-phase electronic speed controller



RMB
Single-phase auto-transformer speed controller